

# Eclipse ThermJet

## Burners

Model TJ0150

Version 2

Parameter	Burner Velocity	Model TJ0150	
Maximum Input BTU/hr (kW)	Medium & High Velocity	1,500,000 (440)	
Minimum Input, On-Ratio BTU/hr (kW)	Medium & High Velocity	150,000 (44)	
Minimum Input, Fixed Air BTU/hr (kW)	Medium & High Velocity	30,000 (9)	
Gas Inlet Pressure Required "w.c. (mbar) Fuel Pressure at Gas Inlet (Tap "B" - see page 3)	High Velocity	Natural Gas	14.5 (36.0)
		Propane	15.0 (38.0)
		Butane	15.5 (39.0)
	Medium Velocity	Natural Gas	7.0 (17.5)
		Propane	6.0 (15.0)
		Butane	6.5 (16.0)
Air Inlet Pressure Required "w.c. (mbar) 15% Excess Air at Maximum Input (Tap "A" - see page 3)	High Velocity	Natural Gas	17.5 (44.0)
		Propane	19.5 (49.0)
		Butane	19.5 (49.0)
	Medium Velocity	Natural Gas	9.5 (24.0)
		Propane	10.0 (25.0)
		Butane	10.5 (26.0)
High Fire Flame Length Inches (mm) (Measured from End of Combustor)	High Velocity	Natural Gas	38 (965)
		Propane	42 (1065)
		Butane	43 (1090)
	Medium Velocity	Natural Gas	43 (1090)
		Propane	42 (1065)
		Butane	44 (1120)
Maximum Flame Velocity ft/s (m/s) 15% Excess Air at Maximum Input	High Velocity	500 (152.4)	
	Medium Velocity	250 (76.2)	
Maximum Combustion Air Temperature	300° (149°C). For higher temperatures, use TJPCA (Data 206).		
Flame Detection	UV scanners available for all combustors. Flamerod available for all combustors and operating temperatures of up to 2,200°F (1,204°C).		
Fuel	Natural gas, propane, or butane. For any other mixed gas, contact Eclipse for orifice sizing.		
Approvals			

- All information is based on laboratory testing in neutral (0.0" w.c.) pressure chamber. Different chamber size and conditions may affect the data.
- All information is based on standard combustor design. Changes in combustor will alter performance and pressures.
- All inputs based upon gross calorific values.
- Eclipse reserves the right to change the construction and/or configuration of our products at any time without being obliged to adjust earlier supplies accordingly.
- Plumbing of air and gas will affect accuracy of orifice readings. All information is based on generally acceptable air and gas piping practices.

## Performance Graphs

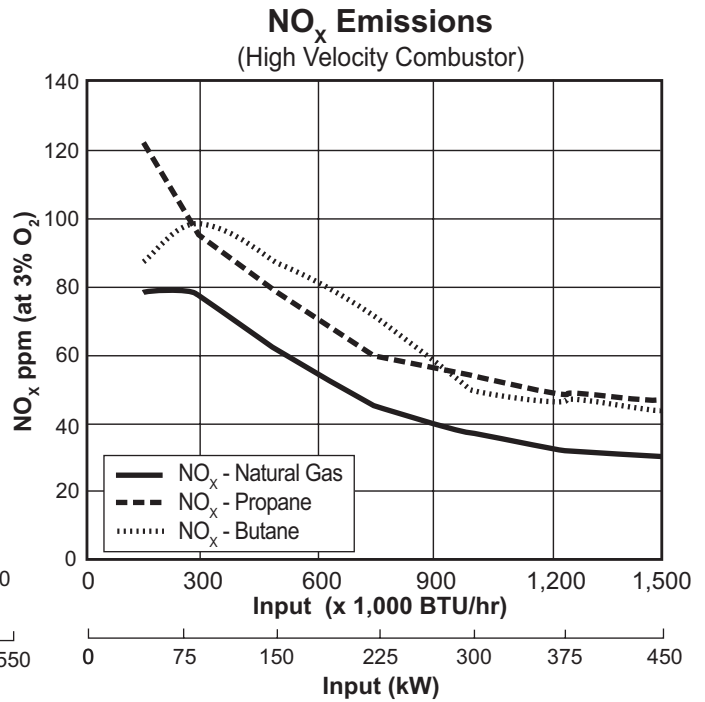
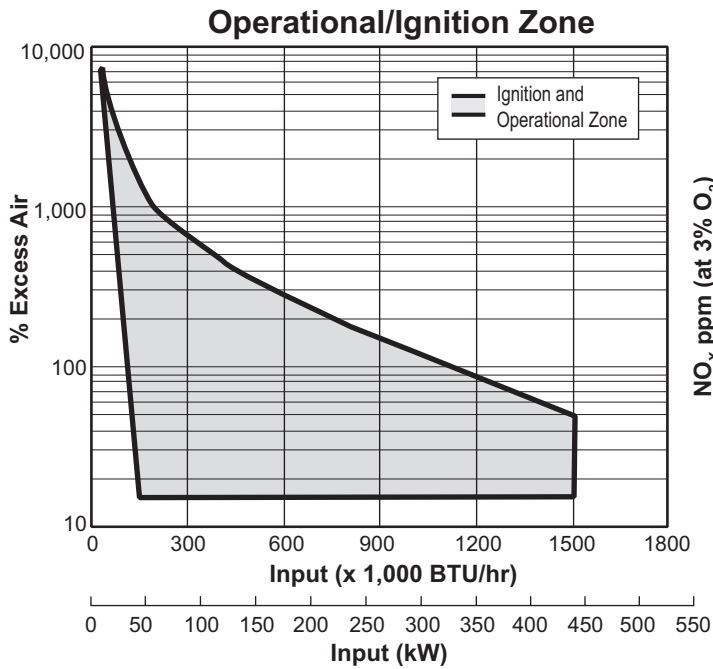

Correction factor for medium velocity combustor is 1.20. Emissions data based on on-ratio control, firing 15% excess air, corrected to 3% O<sub>2</sub>.

Emissions from the burner are influenced by:

- Fuel type
- Combustion air temperature
- Firing rate
- Chamber conditions
- Percent of excess air

For estimates of other emissions, contact Eclipse.

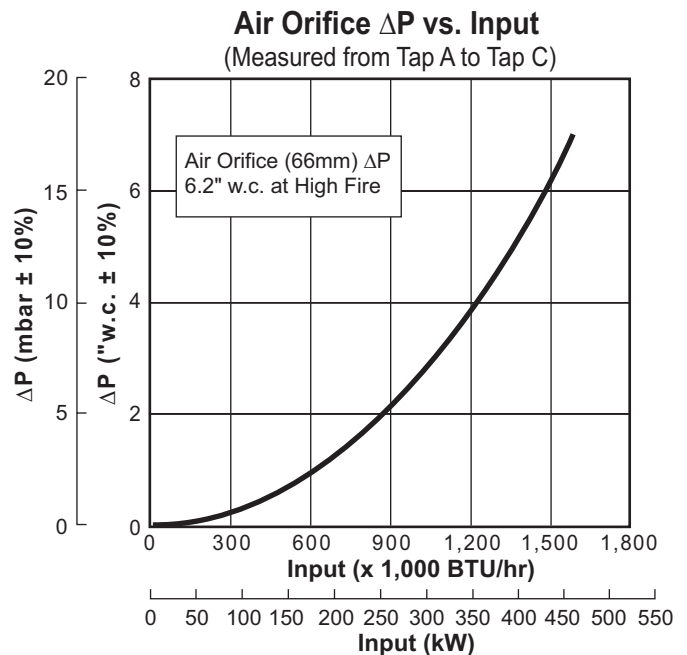
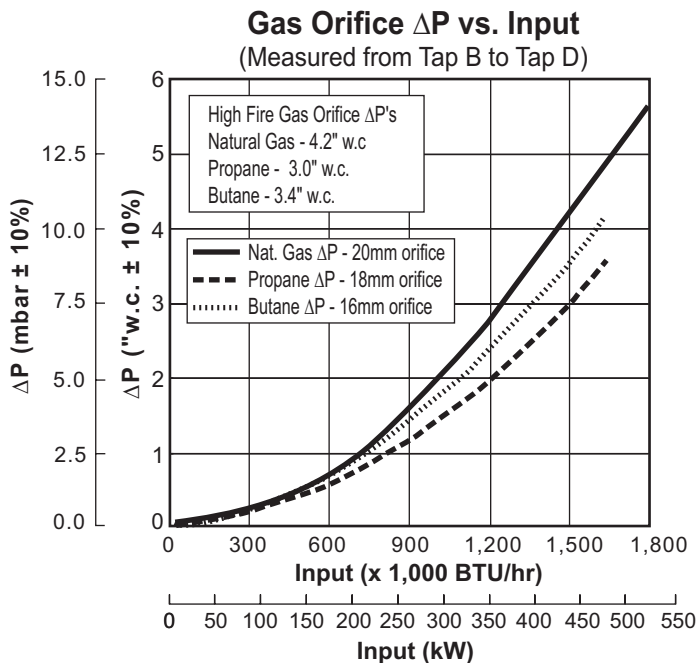

## Dimensions in inches (mm)

### Burner Housing

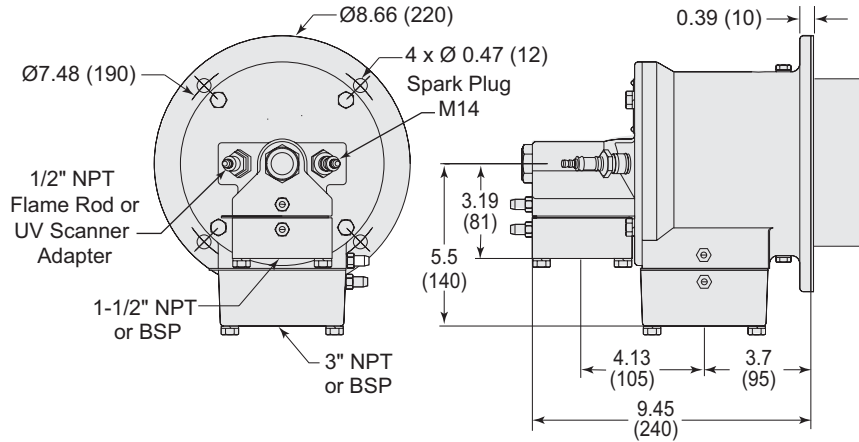

Burner weight less combustor: 42 lbs (19 kg)

### Tap Locations

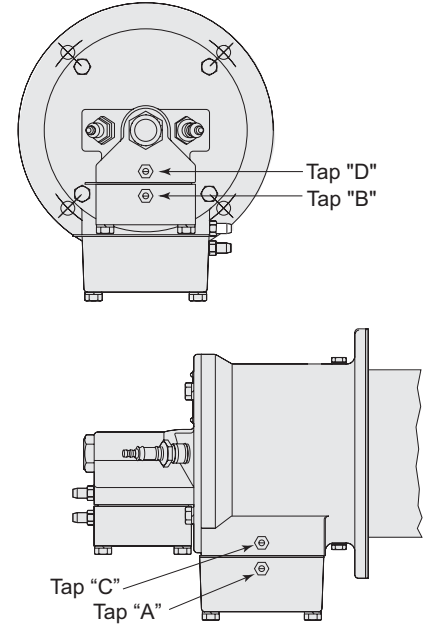

### Combustor

Exhaust outlet diameter: High Velocity:  $\text{Ø}2.5$  (63.5)  
 Medium Velocity:  $\text{Ø}3.5$  (88.9)

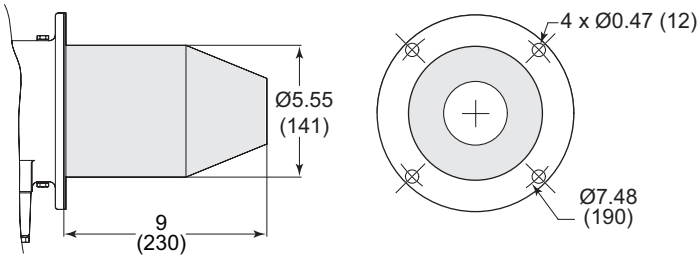

#### Alloy Tube (ANSI 310)

Weight: 3.3 lbs (1.5 kg)  
 Max Chamber Temp: 1,750°F (950°C)

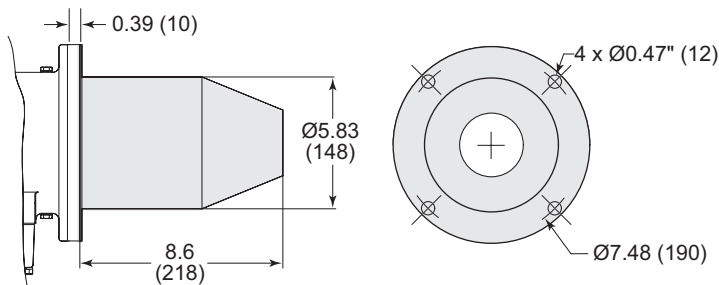

#### Silicon Carbide Tube

Weight: 3.1 lbs (1.4 kg)  
 Max Chamber Temp: 2,500°F (1371°C)

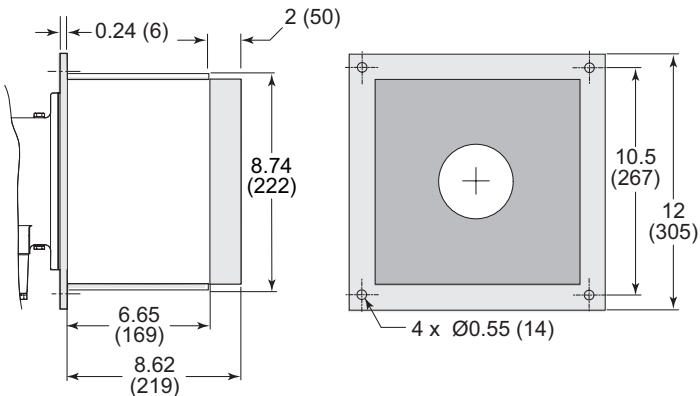

#### Refractory Block

(w/RA330 wrapper)  
 Weight: 58.3 lbs (26.5 kg)  
 Max Chamber Temp: 2,800°F (1538°C)

## Down Firing Block

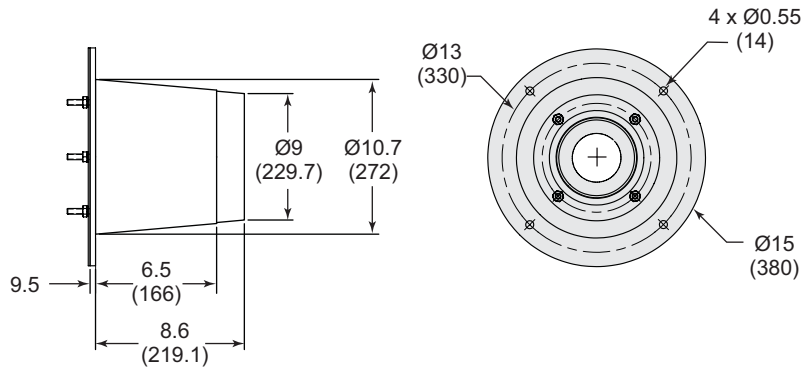

Weight: 75 lbs (34 kg)  
Max. Chamber Temp: 2800°F (1535°C)



**Offered By:**

Power Equipment Company  
2011 Williamsburg Road  
Richmond, Virginia 23231  
Phone (804) 236-3800  
Fax (804) 236-3882

---

[www.peconet.com](http://www.peconet.com)